



QUICK SET LIGHT PORTABLE TRAFFIC LIGHTS

11 Boeing Place, Mount Maunganui 3116 Ph: 07 575 0505

2/11 March Place, Belfast, Christchurch 8051 Ph: 03 323 7507

Email: admin@trafficsigns.co.nz www.trafficsigns.co.nz PO Box 4366, Mount Maunganui South 3149

EXCLUSIVE NEW ZEALAND DISTRIBUTOR Quick Set Light Weight Portable Traffic Lights

FEATURES INCLUDE:

- Inbuilt battery system
- External antenna for extended range
- Removable rugged PTSU lightweight head
- Adjustable tripod height
- Easily added target board
- PTSU can be configured to run single, shuttle and gating modes

SPECIFICATIONS:

- Input Voltage - 5v to 24v DC maximum of 30v and cut-off at 26vdc as per specification of charging circuit
- Battery - 5S2P x 3.2v @7000maH LiFePO4
- Run time - Approximately 15 hours
- Charge time - Full charge in less than 5 hours from low battery warning state
- Each cell is individually monitored
- Signal Aspects comply to AS2144
- Radio Communications - Fully encrypted 900Mhz (256 - bit AES encryption for secure data communications)
- IP45 Rating



DEFINITIONS OF TERMS

The standard definitions listed in Table 1 shall apply to all technical specifications

Definitions – Table 1

TERM	DEFINITION
PTSS	Portable Traffic Signals System
PTSU	Portable Traffic Signals Unit
HRC	Hand-held Remote Controller
Aspect / Lamp / Lantern	A single optical system of a traffic signal lantern, capable of being illuminated at any given time.
Flash Yellow Operation	A signal operation mode where the yellow aspects continually flash

REFERENCE DOCUMENTS

Reference Documents – Table 2

REFERENCE	TITLE
AS4191-2105	Portable traffic signal systems
MRTS265	Transport and Main Roads Specifications MRTS265 Type-2 Portable Traffic Signals
ISO Warning Labels	ISO 2864-2 compliant labels
MUTCD	Manual of Uniform Traffic Control Devices (Queensland)

1. OVERVIEW

Join the safer roads movement with our latest release...the PTL-3 Type-1 PTSS, the PTL-3 Type-1 offers improved safety for Traffic Controllers over the traditional Stop/Go sign, meeting all Australian standards and New Zealand standards, with many extra unique features. Fully designed and manufactured in Australia, this PTL system goes beyond the standards with bonus functions such as in-built chargers, long-life lithium batteries, durable remote controller, optional external battery pack to 50+ hours operation time per charge, plus being the most lightweight unit on the market!

With an ultra-low power consumption (typically less than 7W), the PTL-3 Type-1 operates continuously throughout work shifts, requiring less than 5 hours to fully charge from any 12V vehicle. A lightweight (less than 4.5kg) external power pack allows simultaneous operation and charging of the units to provide 50+ hours of operational time per charge and simply recharges from a vehicle for unlimited operation time.

The lightweight compact design is entirely manageable by one person, with all components weighing less than 7kg. Setup is completed in seconds, simply open the tripod stands and place the lamp units on them and secure them with pins. Now the lights can be activated via the easy-to-use remote controller and the system is immediately operational, a totally effortless process without complications.

2. PTL3 TYPE 1 PORTABLE TRAFFIC SIGNALS SYSTEM FEATURES/SPECIFICATIONS

The PTL3 Type 1 consists of the following features and specifications

2.1 PTL3 Type 1 Portable Traffic Signals Unit (PTSU)

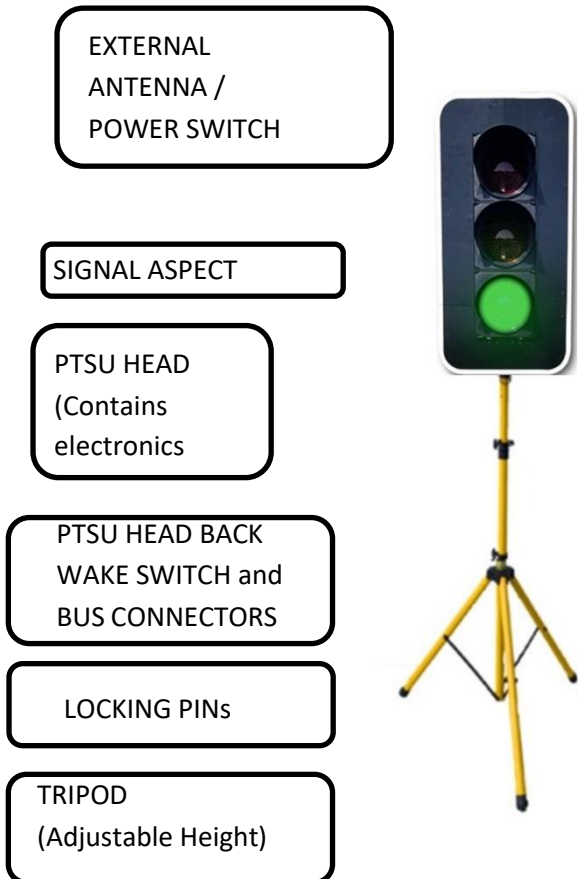

PTSU Unique Features

- Inbuilt battery system
- External antenna for extended range
- Removable rugged PTSU lightweight head
- Adjustable tripod height
- Optional target board
- PTSU can be configured to run single, shuttle and gating modes.

Specifications

- Input Voltage – 5V to 24V DC
- Battery – 5S2P x 3.2V @ 7000mAh LiFePO4
- Runtime – Approximately 18 hours
- Charge Time – Full charge in less than 5 hours from low battery warning state
- Each cell is individually monitored
- Signal Aspects comply to AS2144
- Radio Communications - 915 MHz (256-bit AES encryption)
- IP45 Rating

FIGURE 1 – PTSU

2.2 Specific parts of the PTSU Front view

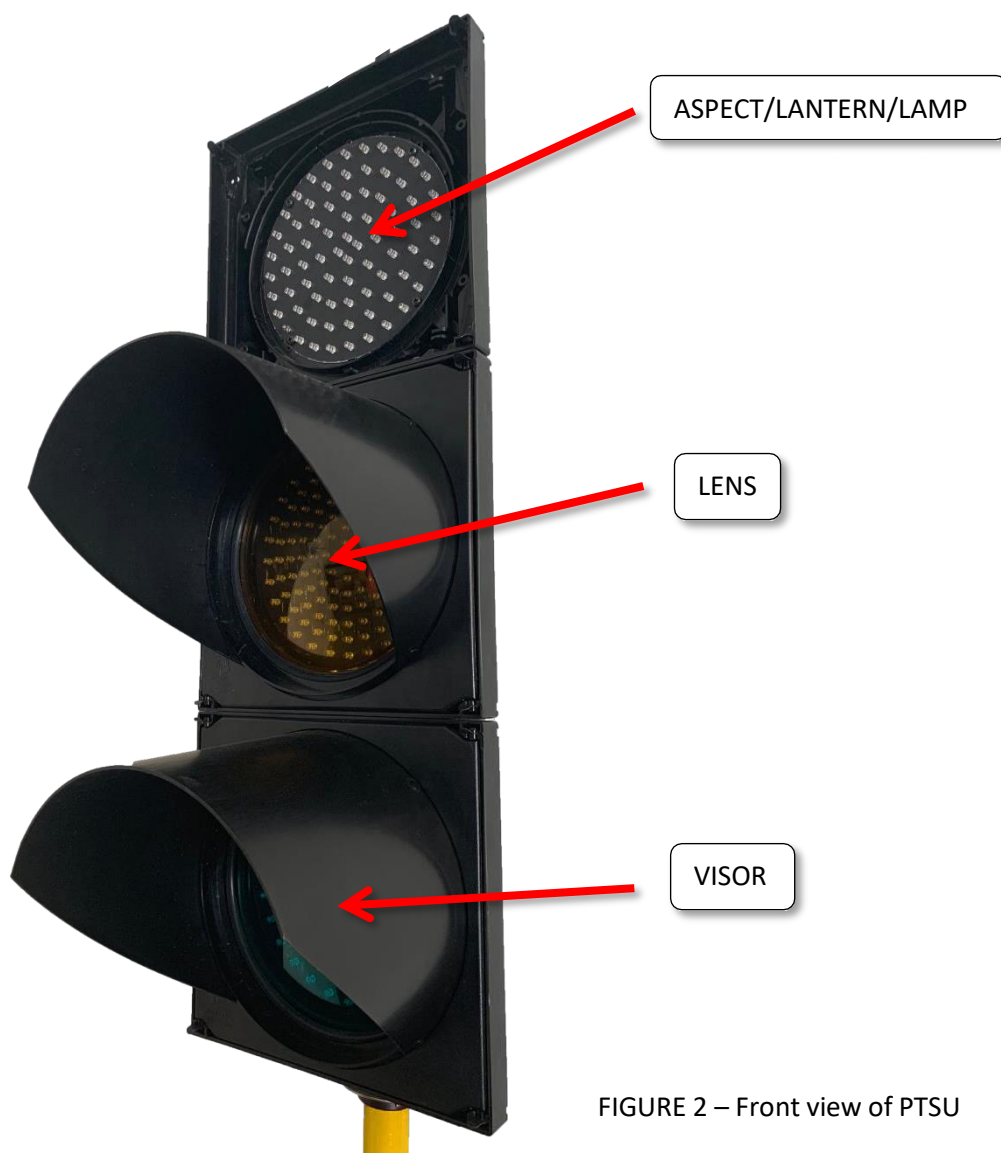

FIGURE 2 – Front view of PTSU

VISORS - Visors are used to increase the aspects visibility in sunlight. These are held onto the lens with 4 securing clips.

LENS - Coloured lenses are used to reduce the effect of veiling reflections, the LED aspects are covered with appropriate coloured lens. The lens is held on the PTSU head with 4 securing clips. These clips can be removed to gain access to the Aspect and PTSU head itself.

ASPECT/LAMPS - A single optical system of a traffic signal lantern, capable of being illuminated at any given time.

Back view



FIGURE 3 – Back view

WAKE BUTTON - The WAKE Button is used for pairing the device with the HRC and also acts as a visual indicator when the unit is being charged.

BUS CONNECTOR - The two BUS connectors are used for charging the unit. There are two connectors incorporated so that the PTSU can be daisy chained together for quick charging.

HANDLE – Used for lifting and carrying the PTSU HEAD.

INDICATOR LAMP – This indicator lamp will flash when the PTSU is displaying a RED Lantern. It will also illuminate when the unit is initially turned on and will go to normal operation once the PTSS is operational.

Top view

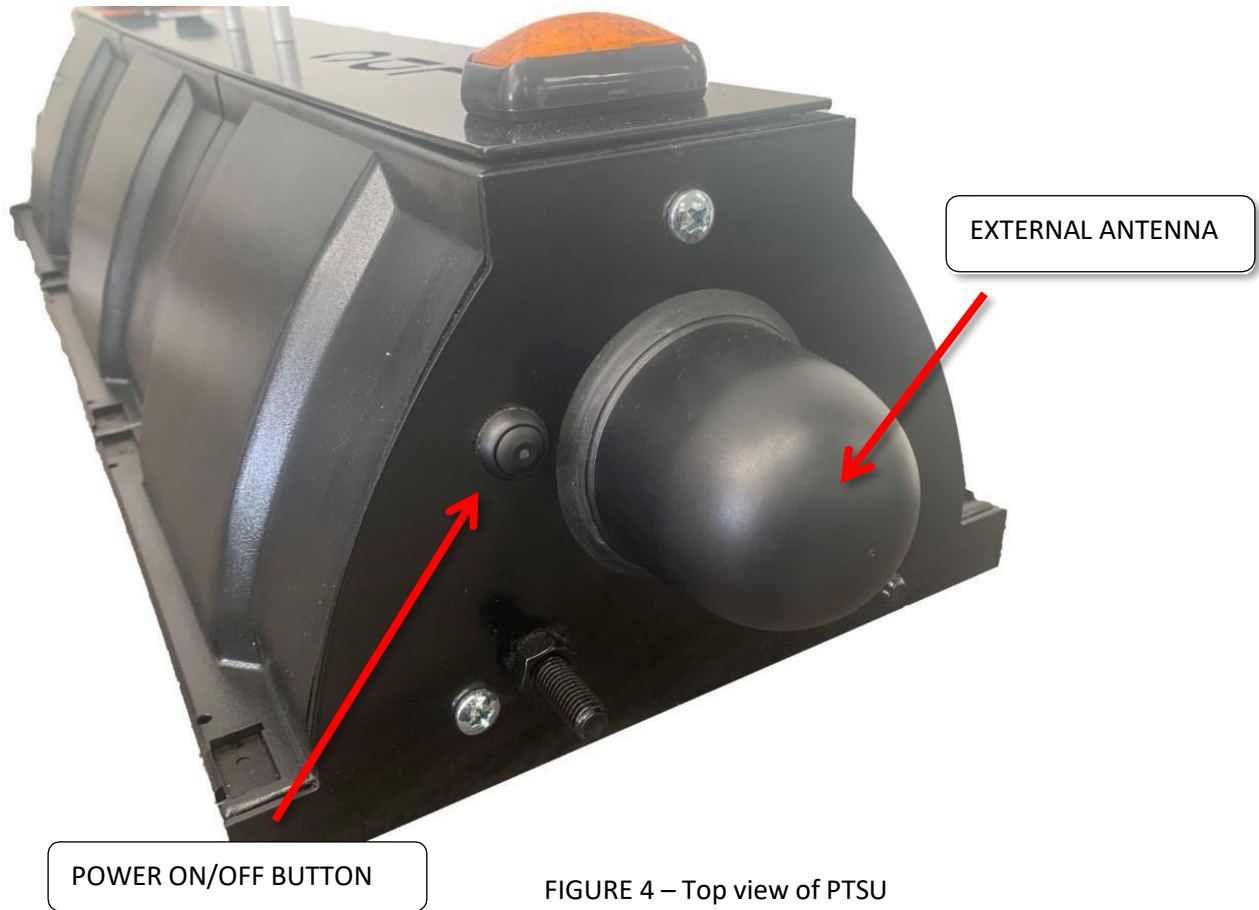

FIGURE 4 – Top view of PTSU

EXTERNAL ANTENNA and CONNECTION - This type of arrangement allows for better reception and range for the PTSS. The antenna connection will need to be checked before operation of the PTSS.

POWER ON/OFF BUTTON - The Power ON/OFF button is located at the top the PTSU which allows it to be hidden away from the general public.

BOTTOM VIEW

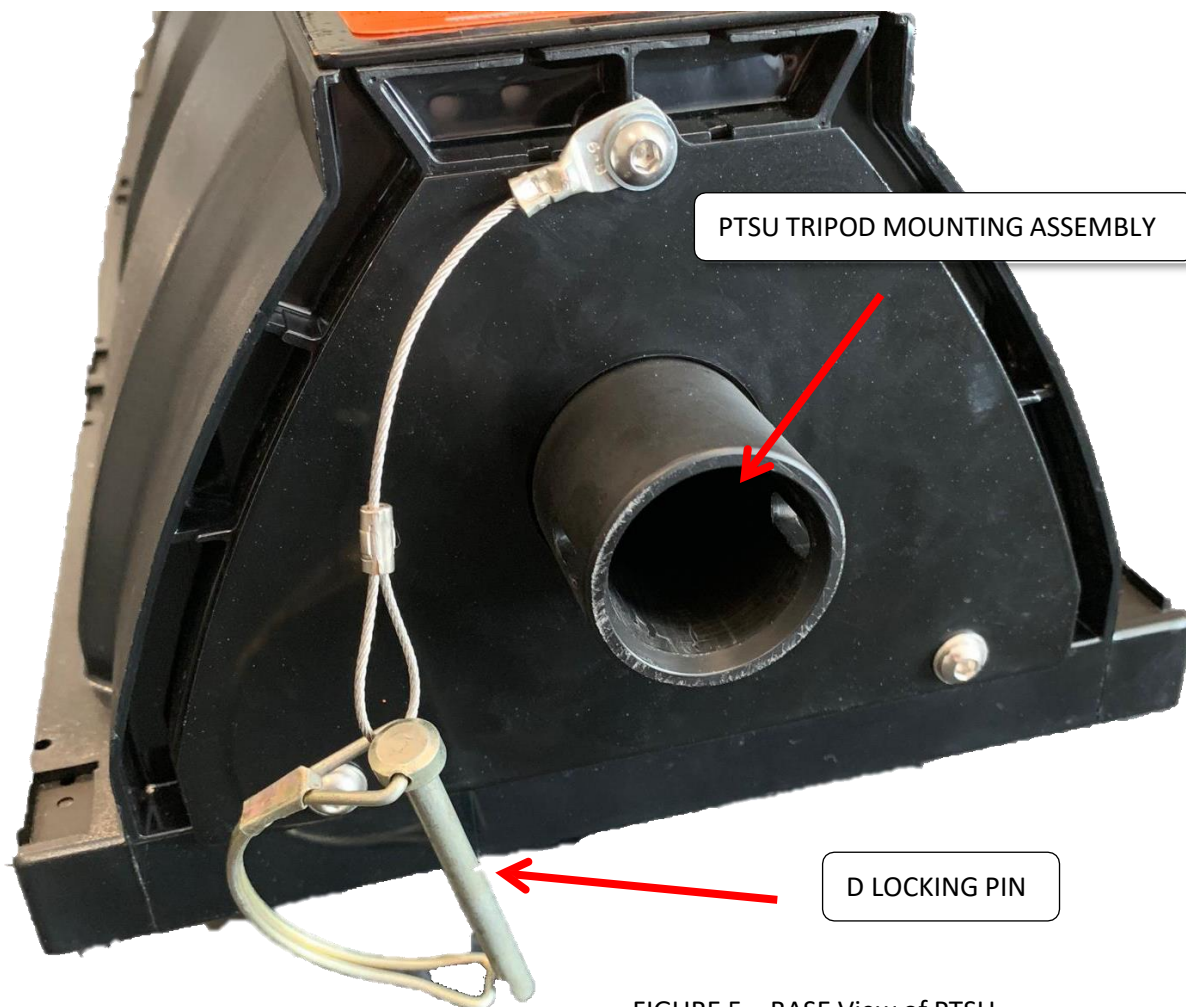

FIGURE 5 – BASE View of PTSU

PTSU TRIPOD MOUNTING ASSEMBLY – Used for mounting the PTSU head to the Tripod

D-LOCKING PIN FOR TRIPOD MOUNT – Used for locking the PTSU head to the Tripod

2.3 PTL3 TYPE 1 HAND REMOTE CONTROLLER (HRC)

Below is an image (Figure 6) of the HRC for the PTL3 Type1 PTSS.



FIGURE 6 – HRC Complete Unit

HRC Unique Features

- Inbuilt Battery System
- External Antenna for extended range
- Sensory Remote that provides feedback to operators
- Large push buttons on HRC for ease of use.

Specifications

- Input Voltage - 5V to 24V DC
- Battery - 2 x 3.2V @ 3500mAh LiFePO4
- Runtime – Approximately 30 hours
- Charge Time – Full charge in less than 2 hours from low battery warning state
- Each cell is individually monitored
- Radio Communications – 915Mhz (256-bit AES encryption)
- IP65 Rating

2.4 Specific parts of the HRC

CHARGING PORT – This connection is used for charging the unit. There is a plastic cover over the connector so that it is not exposed to the elements.

ANTENNA and CONNECTION – This allows for communication between the HRC and the PTSU. The antenna and connection should be checked regularly as part of the maintenance process.

BUZZER – Buzzer which will sound when buttons are pressed or any other fault occurs.

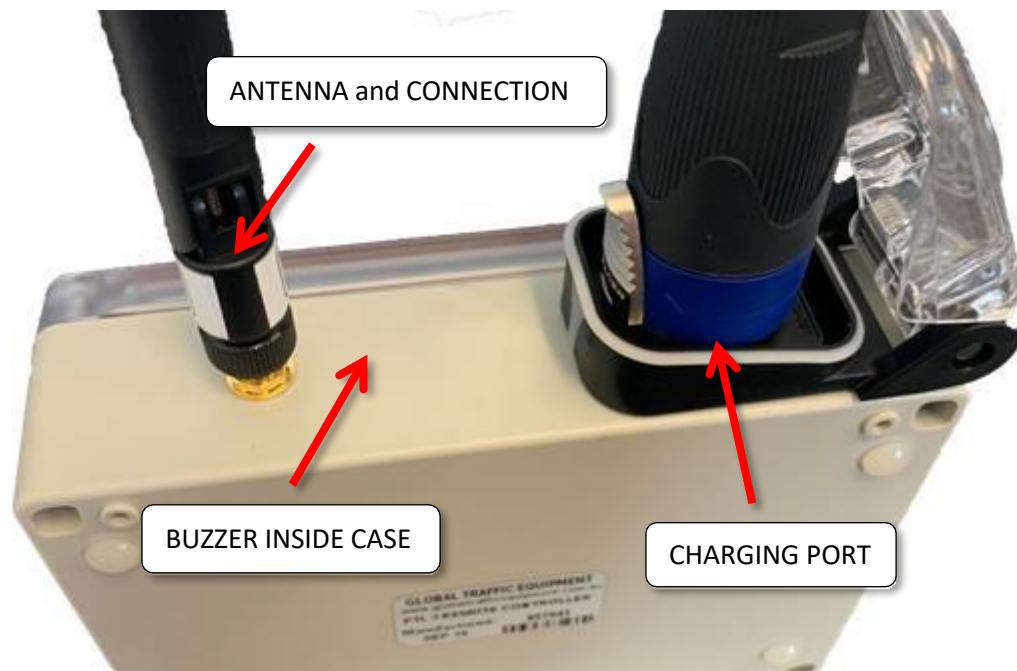

FIGURE 7 – Components of HRC

LID ASSEMBLY – This contains the LCD screen which is back light driven for better visibility, Light sensor and Buttons for the HRC. The buttons are specifically designed to be different colours to allow for easier operation. The Layout for the buttons can be seen in the Figure and their operation will be covered later in the manual.

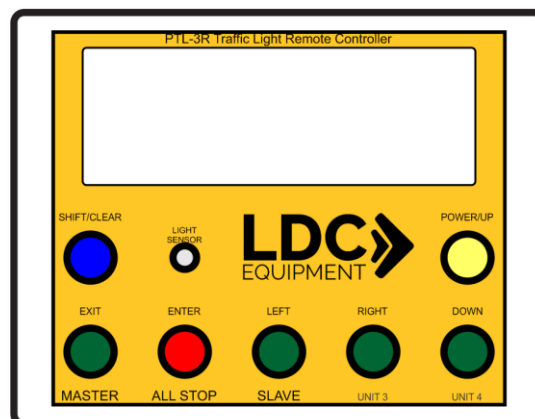

FIGURE 8 – Layout of HRC Buttons

3. IMPORTANT SAFE WORKING INSTRUCTIONS

- **Always use the PTSS in a safe manner**
- **The PTSS is to ONLY be used by trained operators**
- **INSTALL the PTSU in a suitable location that is clear of obstructions**
- **When OPERATING the PTSS, a safe distance between the PTSU and the operator needs to be observed to eliminate the risks**
- **All units, (PTSU and HRC), are to be fully charged and tested before operating the unit**
- **All electrical work on the PTSS should be carried out by Traffic Signs NZ Ltd (TSNZ). Failure to do so may void the warranty**
- **The PTSU, including lanterns, shall be kept clean**
- **All units are to be stored within the casing provided**
- **ALL equipment must be handled with care**
- **READ ALL Instructions before using this equipment**

4. FAIL SAFE TECHNIQUES EMPLOYED

- Only 1 operation can be selected at a time. Interlocks are in place to only allow push buttons to perform certain actions; all other key presses are ignored.
- During normal operation, buttons need to be held for a minimum of 5 seconds before changes are implemented on the PTSS.
- Adequate warning of any low battery or charging problems with the units.
- HRC provides both visual and audible warnings when there is an issue with communication, wiring and lamps.
- Monitoring of tilt and movement of PTSU once installed and setup.
- Charging voltage warning is provided on the HRC and PTSU when the units are placed on charge.

5. SAFE TRANSPORTATION OF THE PTL3 TYPE 1 PTSS

When transporting the PTL3 Type 1 PTSS care must be taken to ensure that both the PTSUs and HRC are placed back into their cases after use. This will ensure that the PTSS units are not damaged during transportation to and from site.

Placing the PTL3 Type 1 PTSS in the case also allows for secure loading of the devices once in the vehicle.



PTSU loaded into the hard case for transporting



FIGURE 10 – HRC Transport Casing

HRC loaded into the hard case for transporting

6. ONSITE PRE DELIVERY CHECK

Table 4 below outlines the Pre Delivery Check before the units are delivered to site.

PRE DELIVERY CHECK – TABLE 4

DESCRIPTION	CHECKED
Tripod Stand (Not Damaged and All locking mechanisms are accounted)	
Locking Pins (Located on bottom of PTSU and top part of the tripod)	
Base Mounting bracket (Located on bottom of PTSU)	
PTSU Head (Not damaged and Clean)	
Lantern Shroud (Secure with all securing clips in place)	
Lantern Lens (Clean)	
Aspects/Lanterns (Operational)	
External Antennas (Fitted and in place)	
Indicator Lamp (Operational)	
Charging cables (Packed in case)	
Battery Voltage PTSU (Fully charged)	
HRC (Not Damaged and Operational)	
HRC Antenna (Fitted and in place)	
Battery Voltage HRC (Fully charged)	

7. ONSITE SETUP/INSTALLATION

7.1 Suitable locations for installation

The visibility of the PTSS has been identified as key factor to consider when selecting suitable locations for installation.

Some of the main points to consider when installing and operating the PTSS are as follows:

- The impact of work vehicles and plant equipment on the visibility of the PTSU.
- Illuminating the PTSU during operations at night.
- Visibility to Motorist at a minimum distance of 2D (where the value of D is the greater value of the range nominated in Table 4.2 of MUTCD Part 3.)
- Position of the PTSU located no further than 1m from the travelled path

7.2 Installation

Remove the Tripod from the bag, place bag into secure location to avoid being lost.
Release the tripod legs by loosen the locking knob in the centre of the tripod.

Loosen the Locking Knob as shown in the picture



Push the shaft down. The legs will spread out.

Extend the legs by pushing down the centre of tripod.
Position the tripod legs so that the leg supports are 90 degree to the main upright.

Support braces are to be 90 degrees to main upright



Don't worry if the unit is not level, the tripod extension leg lengths can be adjusted for uneven surfaces

If the surface is uneven; there are two extension legs that can be extended to level out the tripod.
Place and check the bullseye level and adjust the extension legs until the tripod is level.

Loosen the locking knob. The extension legs will extend. Tighten once correct length



Once the tripod is level, sandbags can be placed on the stand and feet to secure the stand in place



Take the sandbags and place them over the stand and feet to secure the stand in place.



It is recommended to place at least 20kg sandbags per leg

1. Remove PTSU Head from case



FIGURE 13 – PTSU Packed away in transport case

2. Check that antennas are not damaged before operation refer to Figure 14 (Antenna)
3. Turn the PTSU on using the power on/off switch, when the unit is powered the indicator lamp will remain on and place on the tripod.

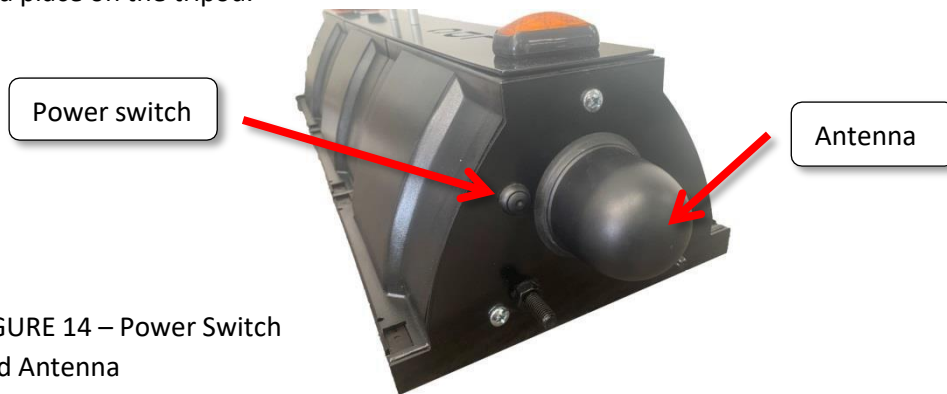

FIGURE 14 – Power Switch and Antenna

4. Secure the head to the tripod by aligning the holes with base and tripod, refer to Figure 15(A). The locking pin can then be inserted refer to Figure 15 (B). Raise the tripod mast to the desired position and insert tripod D locking pin refer to Figure 15 (C).



FIGURE 15 – Securing pins

5. Use the HRC to pair and test the units, this will set the position of the traffic lights once installed. The pairing and testing operation is covered in the manual below.
6. PTSS is ready for operation.

NOTE: WHEN NOT IN USE.

PTSUs when not in use shall face away from traffic or be covered and all signs for the PTSS shall be removed or covered.

7.3 Installation of Target Board (optional depending on visibility assessment)

The aluminium target board is comprised of 3 pieces, the top section and two side sections. The target board has been designed with key way slot to lock into place. The mounting screws can then be tightened to provide a rigid structure.

1. Place the PTSU on a flat surface with the lanterns facing downwards. The PTSU can rest on the visors
2. Install the top part of the Target board using the provided M4 mounting screws.



FIGURE 16 – Top section of Target board Install

3. Install both side parts of the Target board using the keyway slots provided and secure to the top part of the target board using the locking mechanism.



FIGURE 17 – Installation of side sections of Target Board

4. Once secured into position the screws can be tightened to provide more rigidity.
5. The PTSU head can then be lifted onto the tripod using the handle and supporting the base of the PTSU.



FIGURE 18 – Target board installed

7.4 Packing up

1. Turn off unit with HRC ('SYSTEM IS OFF' will be displayed on the HRC Screen)

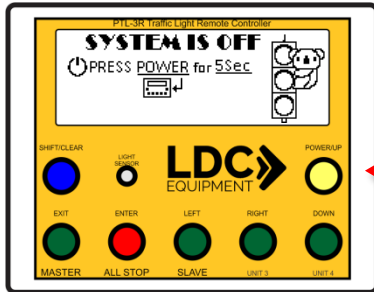

To turn the HRC off,
PRESS and HOLD for 5 seconds

2. Lower the tripod mast by carefully undoing the locking mechanism and removing the tripod locking pin
3. Remove the PTSU head locking pin
4. Remove the PTSU head from the Tripod by grabbing the handle and supporting the bottom of the PTSU.
5. Turn OFF PTSU with the power on/off button.



6. Place the PTSU back in the case for safe transportation and storage.



7. Pack up tripod.
8. Once offsite charge the PTSU and HRC ready for next use. Please refer to the charging of PTSS section in the manual.

PTSS MODES OF OPERATION

The PTL3 Type 1 PTSS can be set for 2 different types of operation modes.

Each of the modes are outlined below.

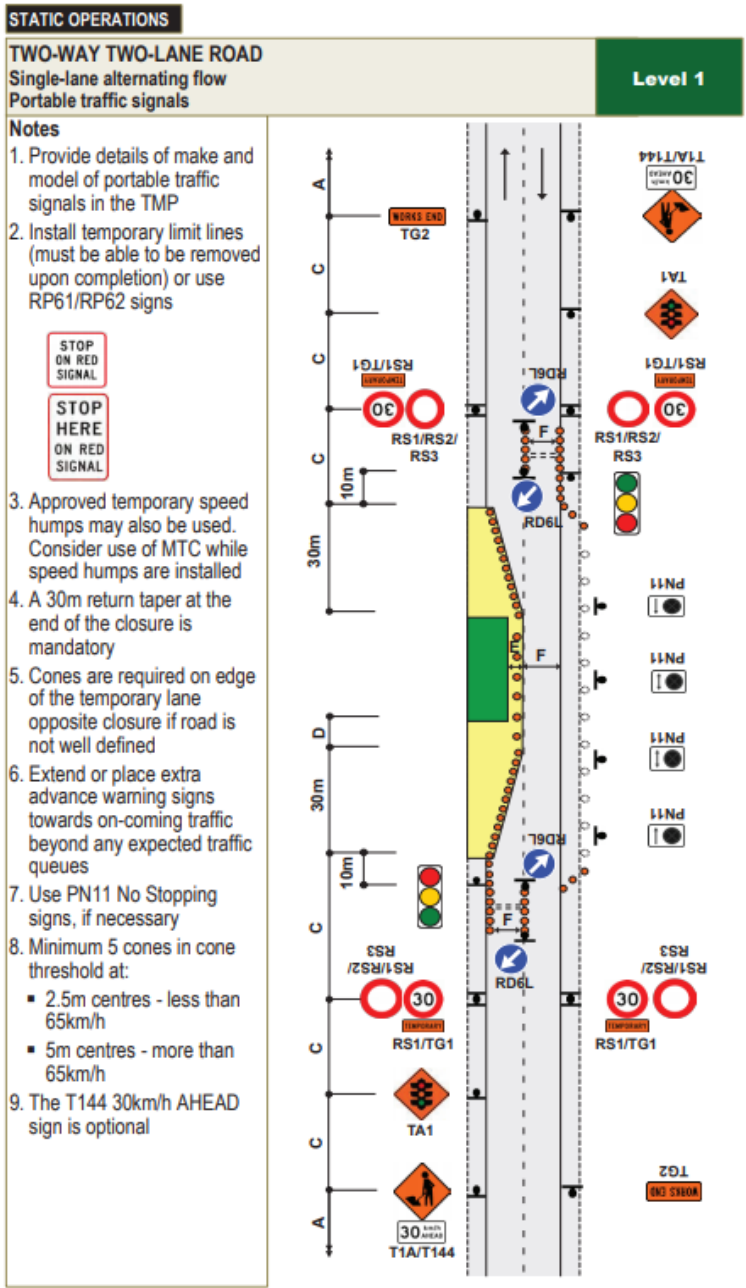

An example of a level 1 Temporary Traffic Management Plan to be used in conjunction with the Quick Set Portable Traffic Lights

- **Single/Gating mode**

Single Mode is where one HRC is controlling one PTSU. This operation mode can also be used for gating control. Gating control is the control of traffic from a single approach.

The normal cycle of lamp operation for both single and gating modes is as follows.

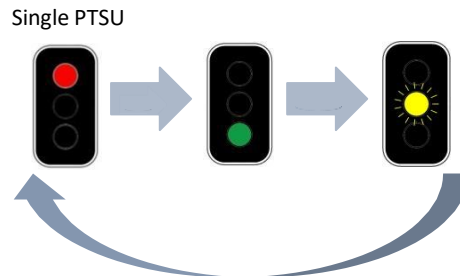

- **Shuttle mode**

Shuttle Mode operation is where one HRC controls two PTSU. “This type of control is generally used on a two-lane, two-way road, where one lane is closed for maintenance and the other is shared by traffic from both approaches.” – MUTCD Part 3.

The normal cycle of lamp operation for shuttle mode is as follows.

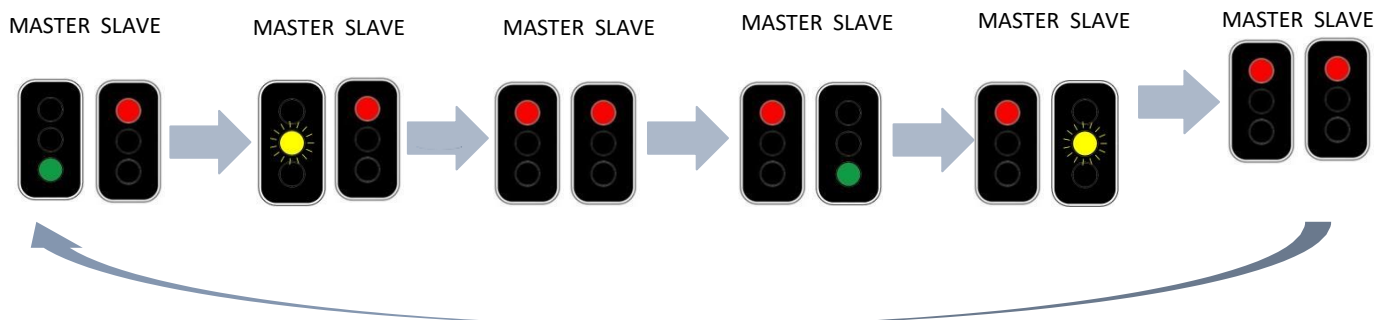

Key Features

- Operators can operate from a safe distance (up to 380m with option to increase distance from HRC and lantern head)
- Can be used as a safer alternative to stop/go or stop/go paddles (or other stop/go alternatives)
- Can be operated with one controller (paired and where there is clear line of sight, subject to conditions)
- Built in safety features and fail safes to ensure operations remain safe
- Environmentally robust, light weight, two-piece assembly, adjustable height (2.5m – 4m)
- Hand remote control (IP45)
- Simple setup and operation of the hand remote control
- Wind loads up to 20.0m/s = 76-88 km/h when used as per manufacturer’s guide – PTL3 with stand and target board – 2 x 20kg sandbags per leg.

Operators

Each lantern requires its own operator unless the following conditions can be met:

- The operator must have clear view of approaching road users for at least 120m in advance of each traffic lantern
- The distance between each traffic lantern is no more than 760m
- The operator is not further than 380m (maximum operatable distance for the remote) from each lantern

Operators Must:

- Be positioned so they are as far as is practicable from live traffic (minimum 1m)
- Be positioned so they are clear of any moving or operating plant and/or machinery
- Not undertake any other task or work activity whilst in control of the traffic lantern(s)

PTSU Operation

Turning ON PTSU

The power switch is located on the top of the PTSU. Press the button so it stays in the downward position. The indicator light will stay solid to indicate that the unit is currently turned on.

Monitor lamp will be illuminated when the PTSU is on

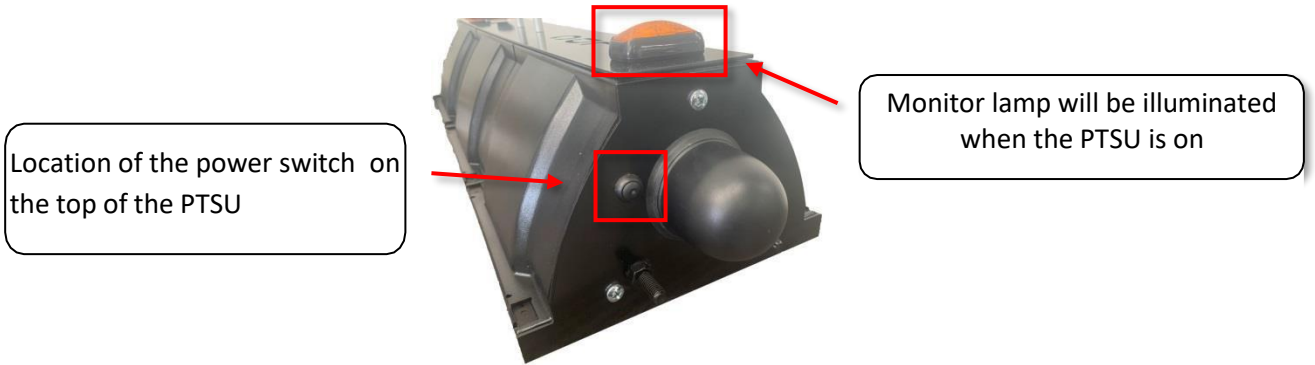

Turning OFF PTSU

The power switch is located on the top of the PTSU. Press the button so that it stays in the upward position. All lights on the unit will switch off.

WAKE switch operation

The wake switch is used to indicate the charge status.

It is also used to wake the system after the unit has been switched off by the HRC.

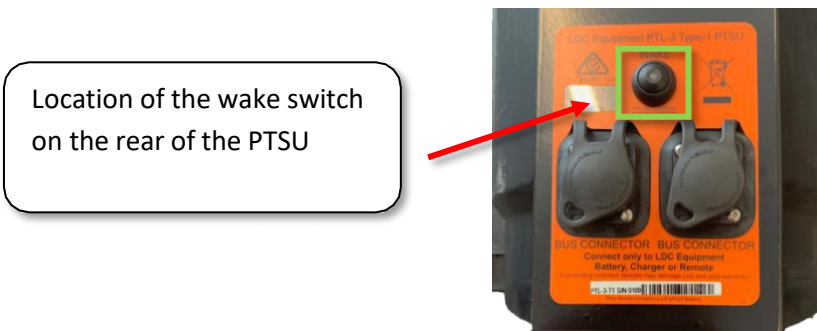

Position sensor

Each of the PTSU units is fitted with a position sensor (accelerometer + magnetometer). If the unit changes its orientation, an error will appear on the HRC and the unit(s) will enter a **flash-yellow** condition.

If the unit needs to be moved whilst in operational mode, the position sensor will need to be recalibrated to the new position. This can be done by orientating the PTSU into the same position or by pressing the WAKE switch on the back of the moved PTSU unit.

If desired, the position sensor can also be switched off. Refer to [Section 15.6 Disabling the position sensor](#) for instructions on how to do so.

Start-up Sequence

The start-up sequence for the traffic light is as follows:

1. When the PTSU is initially turned on the light will remain in the off state (no aspects are illuminated).
2. If the PTSU is paired to the HRC and the HRC is turned on, communication with the PTSU and the HRC will occur.
3. If the units are able to communicate, the start-up sequence on the PTSU will commence.
4. The PTSU will flash the **yellow** lamp for 5 seconds with a duty cycle of 0.5 seconds on and off.
5. The **yellow** signal lamp will remain solid for 4 seconds and then transition to a **red** signal
6. A minimum time of 5 seconds is required on the **red** signal lamp before the unit can be changed to a **green** signal.

Below is a timing diagram of start-up sequence.

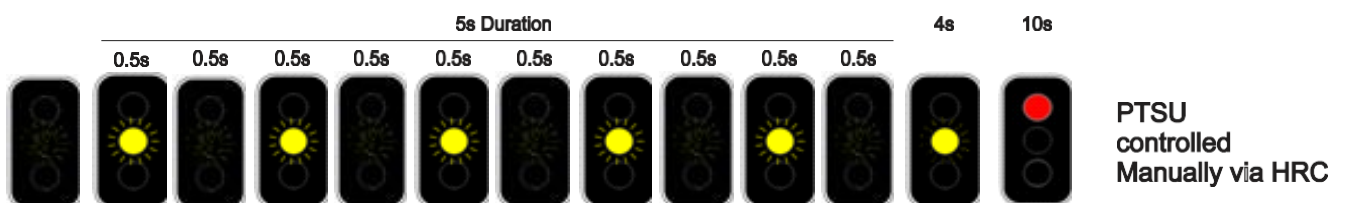

PTSS OPERATION

The sections below cover the basic setting up and operation of the PTSS with the HRC.

Start-up procedure

Ensure that the PTSU are ON. By pressing the Power switch on top of the PTSU, the PTSU will indicate that it's on by illuminating the monitor lamp on the back of the PTSU. All lanterns will be blank until valid communications and self-tests are complete.

1. Turn on the HRC by holding the POWER button for 5 Seconds. The HRC screen will then buzz and beep to indicate the system has been turned on.
2. CHECK THE CONFIGURATION OF THE PTSS. Press and hold both the SHIFT and POWER Buttons on the HRC at the same time for 5 seconds to enter the SETUP Menu.
3. CHECK THE UNITS ARE PAIRED with the HRC.
4. PERFORM A PAIRED TEST on the UNITS to make sure lamps are operational on PTSU.
5. CHANGE THE MODE OF OPERATION as required.
6. ALL OK and commence operation.

The screens that will be displayed on the HRC during start-up are as follows:

1. Power off
2. Start screen with power button count down timer
3. Antenna connected / software versions
4. HRC status
5. Status of PTSU(s), if paired
6. Operational screen

Shutdown procedure

Whilst the unit is in operation mode, TURN OFF the PTSS by holding the POWER button for 5 Seconds on the HRC. The PTSU paired to the HRC will switch off and all lamps will be off. Press the power switch on top of the PTSU to confirm shutdown.

Operating the lights

Flash yellow condition – Press and hold the SHIFT Button until the beep is registered. The PTSU will flash the yellow lamp on and off with a 1 second period and remain on this state until the ALL STOP button is pressed. When exiting the flash yellow condition, the traffic light will run the yellow lamp for 4 seconds before displaying the red condition. The flash yellow condition can only be set when the traffic lights are set in an all-red condition.

Press SHIFT until beep.
Will only flash yellow if red

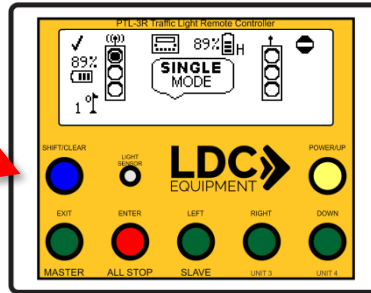

Single/Gating mode (SI)

To change the lights when in operational mode, press either the red ALL STOP button to enter a red state or the green MASTER button to enter a green state.

Red condition – Press and hold the ALL STOP button for 5 seconds on the HRC. If in a green condition, the PTSU will cycle to a yellow condition for 4 seconds and then go to a red condition.

Press ALL STOP until beep

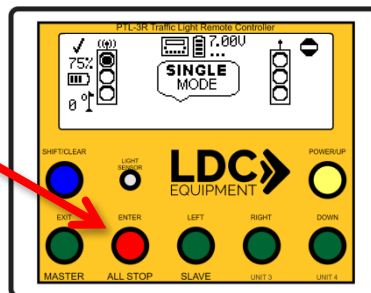

Green condition – Press and hold the MASTER button for 5 seconds on the HRC. The PTSU will change to a green condition. If there is a critical fault (e.g. position error), the command will not be registered.

Press MASTER until beep

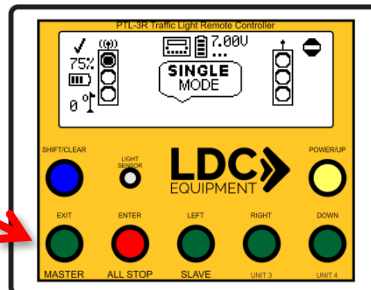

Shuttle mode (SH)

To change the lights when in operational mode, press either the red ALL STOP button to enter a **red** state or the green MASTER button or the green SLAVE to enter a **green** state on the master or slave, respectively.

Red condition - Press and hold the ALL STOP button until beep is registered on the HRC. If in a **green** condition, the PTSU will cycle to a **yellow** condition for 4 seconds and then go to a **red** condition.

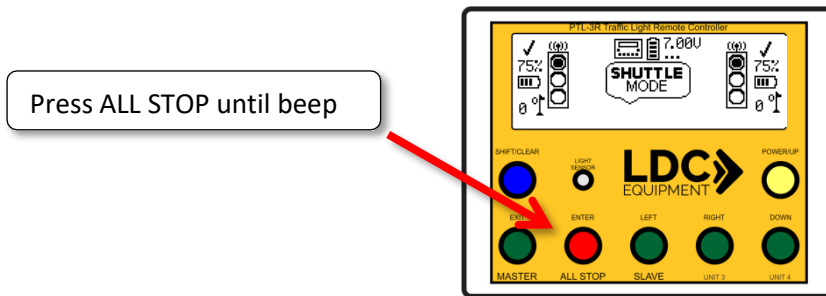

Master green condition – Press and hold the MASTER button until beep is registered on the HRC. The master PTSU will change to a **green** condition.

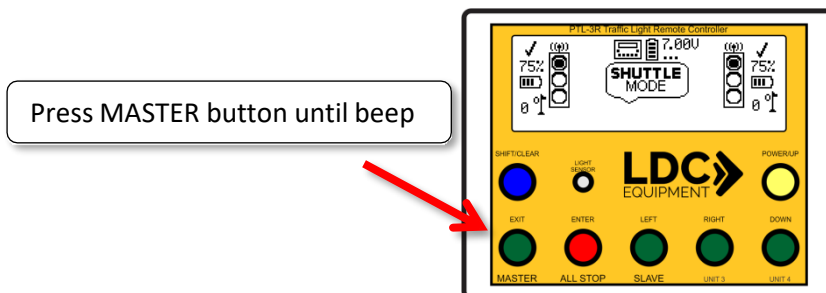

Slave green condition – Press and hold the SLAVE button until beep is registered on the HRC. The Slave PTSU will change to a **green** condition.

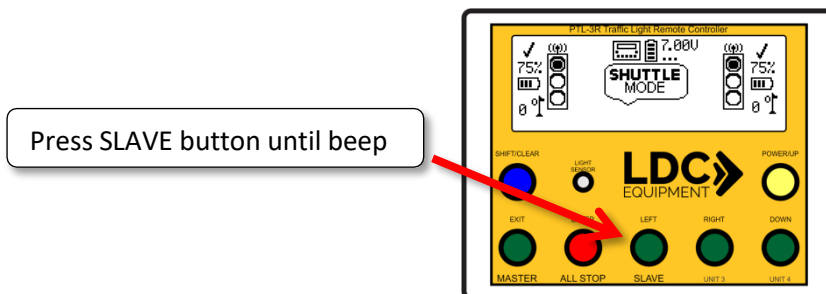

Viewing the PTSS status via the HRC

When the PTSS is running, the status of the PTSU can be checked by pressing the UNIT 3 button for the master unit if running and the UNIT 4 button for the slave unit. There are three information screens provided for each unit. The fourth page always shows the status of the HRC regardless if the master status or slave status was viewed.

The first press of the UNIT 3 button will show the following screen.

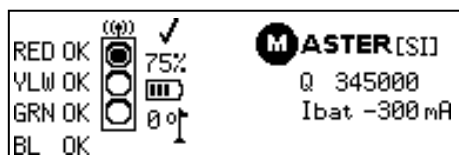

Master unit status, page 1

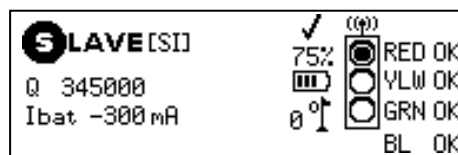

Slave unit status, page 1

This screen indicates the status of the lamps, communication status, battery status, the current configuration of the PTSU, the orientation displacement of the PTSU. It also shows the battery and charger current and battery coulomb count (Q).

The second press of the UNIT 3 button will show the following screen.

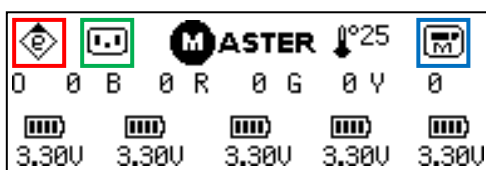

Master unit status, page 2

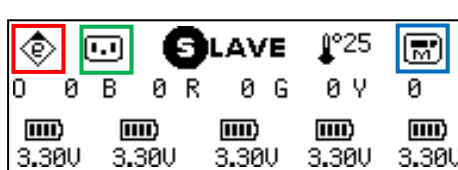

Slave unit status, page 2

The information shown on this screen will indicate the voltage on each battery located inside the PTSU unit. The temperature of the control board is also displayed on the top right-hand corner. The status of the **electronic compass**, **charging circuitry**, and **battery monitor** is also displayed on the top row. If a question mark appears beside any one of these icons, then a fault has occurred with the respective component.

The third press of the UNIT 3 button will show the following screen.

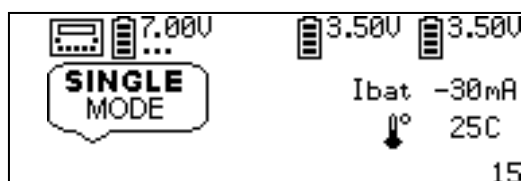

HRC status, page 3

This screen shows the current mode of operation, battery charge status, battery temperature, and the current consumption of the HRC. If the charger is plugged in to the HRC, the display will also show the adapter current measured at the charge port.

Faults in operation modes

If a fault occurs with the PTSS while in operation, the HRC will communicate the fault to the user via audible and visual alerts. The lanterns, however, will not change to a **flash-yellow** condition.

Low battery warning on PTSU

Low battery warning will occur when there is a minimum of one hour runtime on the PTSS. It is recommended that when the 60-minute warning display appears, the units be placed on charge.

The below picture displays the low battery warning that will appear on the HRC.



Master low battery



Slave low battery

If both PTSU and HRC are low on battery, the HRC display will toggle between all the battery warnings.

Critical battery warning on PTSU

The below picture displays the critical battery warning that will appear on the HRC.



Master critical battery



Slave critical battery

When the PTSU battery reaches a critical level, a 3-minute warning will be displayed on the HRC. After approximately 3 minutes, the PTSU will shut down to protect the battery. Do not continue to use the PTSU without charging it otherwise the battery may be damaged.

Low battery warning on HRC

Similar to the low battery warning on the PTSU, the HRC will also display a low battery warning when there is approximately 60 minutes of run-time remaining on the HRC. It is recommended that when the 60-minute warning display appears, the HRC be placed on charge.



HRC low battery warning

Critical battery warning on HRC

Similar to the critical battery warning on the PTSU, the HRC will also display a critical battery warning when there is approximately 3 minutes of run-time remaining on the HRC.

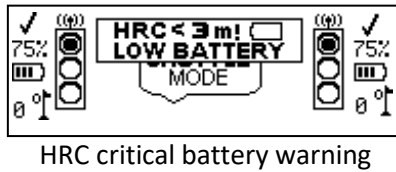

To continue using the HRC, plug in a charger immediately otherwise the HRC will shut down to protect the battery.

Critical faults in operation modes

Critical failures can occur whilst in operation mode. The following describes the critical errors that will be displayed on the HRC whilst in operation.

If any critical failures do occur whilst in operational mode, the PTSS system will automatically set all connected PTSUs to a **flash-yellow** condition so issue can be dealt with by Traffic Control. The PTSU(s) cannot be controlled until the critical fault(s) have been rectified.

Position error on PTSU

The unit has rotated/moved from its original set position. The light will need to be positioned back into this position and then changed back to operational state. The position error will indicate which PTSU has moved position. The below picture displays the error that will be displayed on the HRC.



Master position error



Slave position error

Lamp issues – disconnected or malfunctioning

If a lamp is not drawing the expected amount of power from the lamp controller board, this will be displayed on the hand remote controller unit as a fault. This could be due to a bad connection or a faulty lamp. All connected PTSU(s) will go to a **flash-yellow** state and the HRC will display the fault on the screen accompanied an audible warning. If lamp errors do occur, the test sequence on the lamps will need to be performed to clear the error.

Communication error

If the operation is adversely affected by conflicting commands or radio issues (out of range, bad signals) the HRC will display a communication error and the PTSS will go to a **flash-yellow** condition.



Disabling the position sensor

The position sensor on the PTSU(s) can be temporarily disabled if desired. While the HRC is on the operational page, press and hold the SHIFT button and MASTER/SLAVE button for 5 seconds to turn off the position sensor on the master or slave unit, respectively. The HRC will beep and vibrate for an extended duration to confirm that the position sensor has been switched off. Once disabled, the position sensor can be re-enabled by pressing the same key combination again. The HRC will beep and vibrate briefly to confirm that the position sensor has been enabled.

The status of the position sensor is indicated via the flag icon beside master/slave PTSU status display.

For safety, the position sensors will be re-enabled automatically upon the next bootup of the HRC.

PAIRING GUIDE



1. Press down on **POWER** button on each LDC lamp.

This button is to be found at the top of each traffic light lamp

2. Hold down the **POWER** button on the LDC Controller, until a count down timer appears. Unit will illuminate upon success of function.



3. Once unit is powered up, the Single/Shuttle mode will show on the left of screen



4. Hold the **SHIFT & POWER** button down for 5 seconds to access the Set Up Menu. See countdown from 5 to 0 to confirmation beep.



- Once in the Set Up Menu, the Select Mode and Pair Set Up is visible



- Each button corresponds to the controller picture on the screen.

In the example below, the pair setup screens corresponds to the **UNIT 3** button on the controller



7. By pressing the **UNIT 3** button, you gain access to the Pairing Menu.



8. On the rear of the lamp, you will find a **WAKE** button. Press this for 3 seconds.

A 16 digit number will appear along the bottom of the screen



9. Press the **MASTER** button to lock the Lamp to the **MASTER** Button on the Controller that you are pairing with. Hold down until confirmation beep is heard.



A Key chain at the top left will indicate the pairing is successful.



10. Press the **ALL STOP** button to Exit out of the Set Up Menu.

12. If you wish to use one controller to operate both lamps, the above procedure is the same. However when in the Setup Menu, press Shift to change to Shuttle Mode.



13. Enter pair Setup and repeat steps 8 & 9 In addition to this, press the Wake Button on the additional lamp. Pair the additional lamp to the Slave Button. Exit from the Setup Menu and you will be prompted with the Waiting Screen.

Wait 20 seconds and the controller will now be paired to both units.



CHARGING OF PTSS

As all parts of the PTSS run on a battery system, care must be taken to ensure all units are placed on charge correctly ready for full operation for the next use. The following section covers both the charging on the PTSU and the HRC and any issues that arise with charging the units.

The unit can be charged whilst it is operational. However, it will charge at a slower rate to reduce interference to the electronic compass.

Be sure to charge the PTSU and HRC in an environment between 0°C and 40°C to prevent damage to the internal batteries. Should the temperature of the batteries exceed this range during charging, the unit will automatically pause charging until the temperatures fall within the specified range.

PTSU charging

7. Connect the charger to a power outlet.
8. Plug the charging plug into the back to the PTSU.
9. The LED light on the WAKE switch will flash periodically (1 Hz) to indicate that the unit is currently charging. If the LED blinks a sequence, refer to [Appendix D – WAKE SWITCH LED FAULT CODES](#) to identify the fault.
10. Once the unit is fully charged, the LED light on the WAKE switch will illuminate steadily.
11. Another PTSU can be charged by connecting the pairing cable from one unit to the next unit in a daisy chain type of arrangement. The charger is only capable of charging two PTSU and one HRC in the daisy chain arrangement.



HRC charging

12. Connect the charger to the power outlet.
13. Plug the charging cable into the HRC.
14. The screen will indicate the charge status. If the HRC is in operation, the HRC will display a power cord icon to indicate that the unit is charging. If a temperature icon is displayed instead, the HRC has paused charging due to low or high battery temperature.
15. When charging is complete, the HRC will flash a 'HRC CHARGED' message.

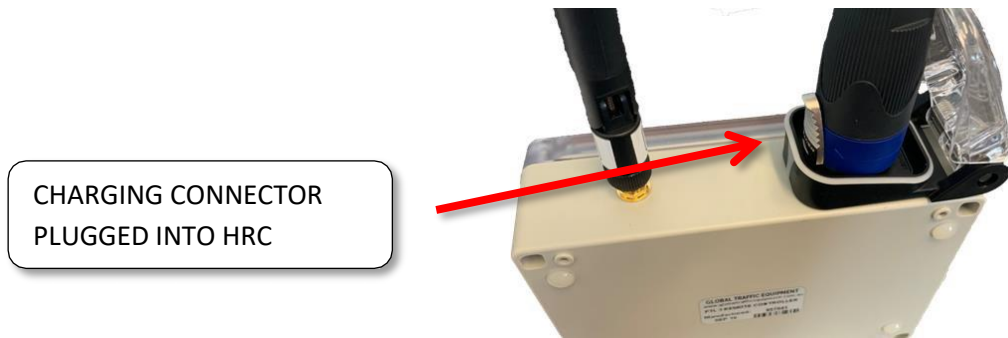

All operations allow the units to be charged whilst in operational mode.

For more information on the icons displayed on the HRC screen, refer to [APPENDIX A HRC ON-SCREEN ICONS](#).

Connection of external battery pack to PTSU

The External battery pack shown below is an optional accessory to the PTSS. This external battery pack allows for extended run times of the PTSS.

Use the PTL3-CL cable to connect from the external battery box to the back of the PTSU. The wake button on the back of the PTSU will start flashing to indicate that the unit is currently taking charge from the external battery pack.

Once the PTSU is fully charged it will turn solid red. If the traffic lights are currently running, then the external battery pack will operate as an external power source and will attempt to charge the batteries within the PTSU but will never reach fully charged as the power is constantly being used by the PTSU.

If there are no lights on the back of the traffic light head, check the status of the external battery pack to see if the external battery is charged and also check the internal fuse within the external battery pack.

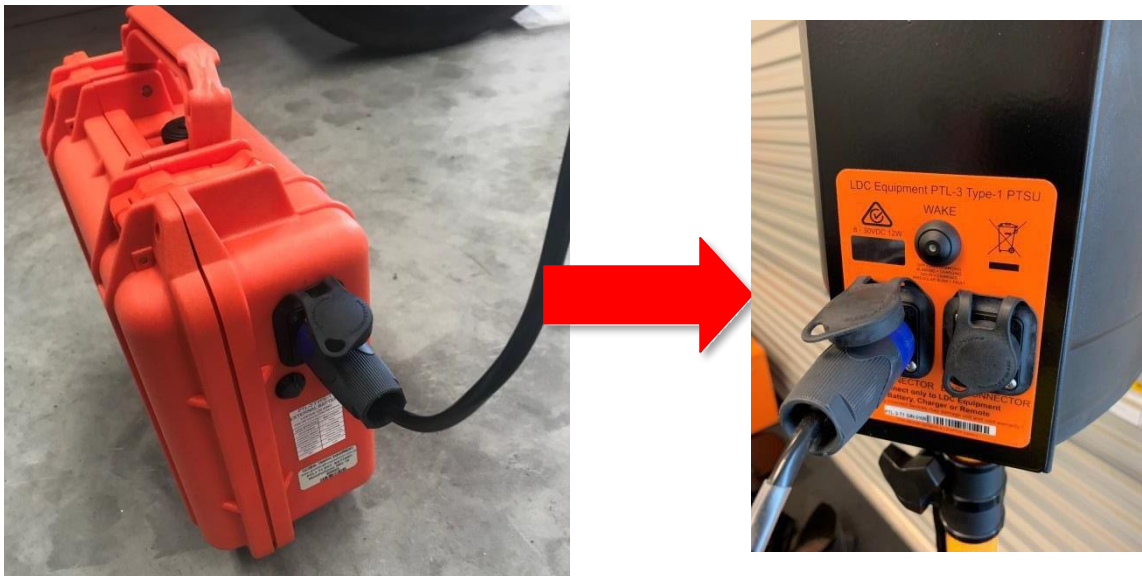

PTL3 cable connection from External battery to lamp head

SAFE MANUAL HANDLING PROCEDURES FOR BATTERIES

To prevent the possibility of the cells from leaking, heating or explosion, please observe the following precautions:

- Don't immerse the battery cell in water
- Don't use, or leave, the battery cell near the heat source such as fire or heater.
- During charging, use a specific lithium battery charger only
- Don't reverse the positive and negative terminals
- Don't connect the cell to an electrical outlet directly.
- Don't discard the cell in fire or heater.
- Don't connect the positive and negative terminal with metal objects directly
- Don't transport and store the cell together with conductive objects such as necklaces or hairpins.
- Don't strike, throw or trample the cell.
- Don't pierce the cell with a nail or other sharp object

Caution

- Don't use or leave the cell at very high temperature conditions (for example, strong direct sunlight or a vehicle in extremely hot conditions)
- If the cell leaks and the electrolyte get into your eyes, don't wipe your eyes, instead, thoroughly rinse these with clean running water for at least 15 minutes and immediately seek medical attention. Otherwise, eye injuries can result.
- If the cell gives off an odour, generates heat, becomes discoloured or deformed, or in any way appear abnormal during usage, recharging or storage, immediately remove it from the device or cell charger and stop using it
- If the cell terminals are dirty, clean the terminals with a dry cloth before use
- If the cell is no longer functioning, please fully discharge, then place it into a specialised recycle bin for recycling. There are local companies in the area that will recycle the cells.



WORKPLACE HEALTH AND SAFETY

REQUIREMENTS

OSH Legislation requires a proactive approach to using the Portable Traffic Signal System (PTSS) in the workplace. Certain aspects need to be covered in order to eliminate and minimise the risk to the people who use this piece of equipment.

Adequate Training on using the product needs to be implemented to help identify the risks of using it within the workplace.

All aspects of workplace health and safety cannot be covered in this document due to different company policies and plans currently in place, however the following key points for the product are outlined below:

Key points

TRANSPORTATION OF PTSS

DO:

- Always ensure that all components of the PTSS are placed within casings provided
- Always secure the casings of PTSS for transport
- Lifting of transportation case is a two-man lift due to the length of the case. Once secured on the vehicle, the case will not usually be removed
- All equipment should be handled with care

DO NOT:

- Relocate the Portable Traffic Signals Unit (PTSU) whilst connected to Tripod

SETUP OF PTSS

DO:

- Always install the PTSU's in a suitable location that is clear of obstructions
- Always install all locking pins on the PTSU and tripod and ensure these are installed correctly
- Always setup the tripod on a level surface
- Always sandbag the tripod whilst setting up for operation
- Ensure that the tripod is stable before placing on the PTSU head
- Care must be taken when installing the PTSU head on the tripod

DO NOT:

- Raise the tripod to its maximum height as this will compromise the stability of the unit

OPERATION OF PTSS

DO:

- PTSS is only to be used by trained operators
- Always use the PTSS in a safe manner
- All units (PTSUs and HRC) are to be fully charged and tested before operating the PTSS
- When Operating the PTSS, a safe distance between the PTSU and the operator needs to be observed to eliminate risks
- The PTSU including the lanterns, should be kept clean

DO NOT:

- Look directly into the lanterns whilst operating.

Charging of PTSS

DO:

- Always visually inspect the connections prior to connection to PTSS
- Always allow charger to complete charge cycle

DO NOT:

- Unplug the charger by pulling leads, always hold plug
- Submerge the plugs in water.

Regular reviews of this document will be undertaken with the aim of continual improvement. Therefore we seek the co-operation of customers and other parties. We encourage suggestions for enhancing our workplace health and safety objectives to create a safe working environment with a zero accident rate.

MAINTENANCE

The following maintenance should be checked and carried out on a regular basis.

Inspection

- Check Batteries for swelling, cracks and leaks.
- Check Battery terminals and connections to make sure these are clean, free of dirt, fluids and corrosion
- Check the Antenna for any damage and antenna connection is clean, free of dirt, fluids and corrosion
- Check all lens doors, clips and shrouds are in place.
- Check bottom base plate for any visible signs of damage.
- Check for any damaged cables
- Check for any damage to the unit

Routine

- Turn the PTSU off when not in use.
- Charge the units after every use.
- Clean the Lamp Lens with a damp soft, non-abrasive cloth to remove any dust or dirt that may impair light clarity.
- Store unit within the cases provided
- Charge the HRC once a month when not in regular use.
- Charge the PTSU once every three months when not in regular use.

REPAIRS AND SERVICING

All repairs and servicing of the PTSS shall be performed only by TSNZ technicians.

SPECIFICATIONS

Manufacturer Global Traffic Equipment

Model PTL3 Type 1 PTSS

PTSU

Electrical Specifications	
Nominal operating voltage	16 VDC
Power consumption	6 W (max)
Recommended adapter input voltage	12V – 24 VDC
Internal battery configuration	5S2P LiFePO4 3.2V @ 7000mAh
Charger power consumption	35 W (max)
Charge duration	5 hours
Expected run time (discharge rate)	18 hours (45 Hours with External Battery Pack)
Lantern	200 mm LED Vehicle Lanterns meets all requirements of AS2144-2002
Lens	Coloured lens in compliance with colour requirement AS2144-2002
Radio frequency	902 MHz to 928 MHz (FHSS)
Radio output power	20 dBm, 27 dBm, 30 dBm (configurable)

Mechanicals	
Length	1020 mm
Width	260 mm
Height	400 mm
Tripod	3.65 kg
Lamp Head	7.1 kg
Target Board	1.8 kg
Total Weight	10.75 kg (12.55 kg with Target Board)

PTL3 w/ stand

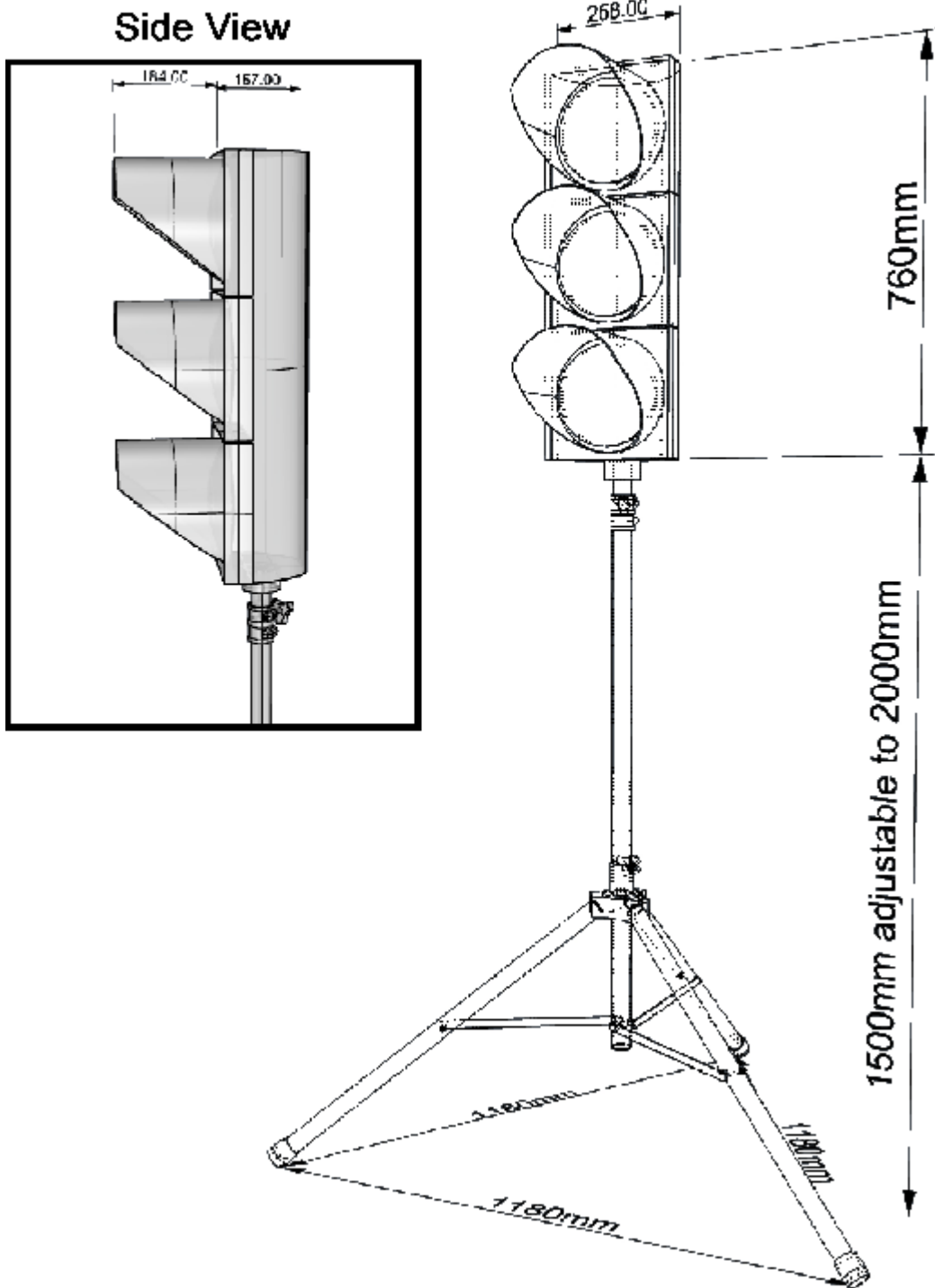

HRC

Electrical Specifications	
Nominal operating voltage	6.4 VDC
Power consumption	0.6 W (max)
Recommended charge voltage	12 V – 24 VDC
Internal battery configuration	2 x LiFePO4 3.2 V @ 3500 mAh
Charger power consumption	8 W (max)
Charge duration	5 hours
Expected Run Time (Discharge rate)	30 hours of continuous use
Radio frequency	902 MHz to 928 MHz (FHSS)
Radio output power	20 dBm, 27 dBm, 30 dBm (configurable)

Mechanicals	
Length	146 mm
Width	106 mm
Height	46 mm
Total Weight	650 grams

WARRANTY

All of LDC's equipment has a reputation for quality, reliability and simplicity in design and use. While quality is our number 1 priority, we understand and appreciate that while every effort is made to ensure every product is 100% fault free in operation and finish, unexpected things can unfortunately occur.

Our Commitment to you, our valued Customer, is if this should happen, we will stand behind our products proudly and make all efforts to rectify the issue as quickly and effectively as possible.

Limited warranty

LDC EARTHMOVING EQUIPMENT PTY LTD, ("LDC") & Traffic Signs NZ Ltd (TSNZ) hereby warrants to the Original Purchaser, as those terms are defined herein, and subject to the provisions, limitations and exclusions in this limited warranty, that its new product or new component purchased from LDC or an Authorised Distributor shall be free from defects in material and workmanship under normal use and service for the periods stated below, and subject to the provisions, limitations and exclusions in this limited warranty.













This limited warranty covers material, workmanship and repair labour cost as to those items specifically listed below for the periods specified. Such repair labour shall be performed only by TSNZ technicians approved by LDC EQUIPMENT.

PRODUCT	WARRANTY PERIOD
	<i>To the original purchaser only (Non-transferable)</i>
Portable Traffic Signals System (PTSS)	12 Months
Spare Parts (excluding warranty service)	12 Months
Service (excluding warranty service)	6 Months

DISCLAIMER

This document provides information on our product and all efforts are made to ensure the accuracy of the information contained within. The specifications of the product are subject to change and continual improvement without notification.

APPENDIX A – HRC ON-SCREEN ICONS

Icon	Meaning
	The respective PTSU is currently operational. No faults have been detected.
	A non-critical fault has occurred with the respective PTSU. Check the warning message on the HRC screen and refer to APPENDIX B – HRC WARNING MESSAGES .
	A critical fault has occurred with the respective PTSU. Check the error message on the HRC screen and refer to APPENDIX C – HRC ERROR MESSAGES .
	Referring to the HRC unit itself.
	The HRC is currently connected to the respective PTSU.
	The HRC is currently disconnected from the respective PTSU.
	Fault with the respective battery cell.
	Charging circuitry on the respective PTSU has malfunctioned. If the question mark is not present, then the charging circuitry is operating normally.
	Battery monitoring circuitry on the respective PTSU has malfunctioned. If the question mark is not present, then the charging circuitry is operating normally.
	The electronic compass on the respective PTSU has malfunctioned. If the question mark is not present, then the charging circuitry is operating normally.
	Position sensor enabled on the respective PTSU.
	Position sensor disabled on the respective PTSU.

APPENDIX B – HRC WARNING MESSAGES

HRC warning message	Description	Remedy
M./S. BAT UNDER-VOLTAGE	One or more cells in the master/slave unit battery pack is below 2.5 V.	Charge the respective PTSU. If the error reappears, then the battery pack may be faulty and require replacement.
M./S. BAT OVER-VOLTAGE	One or more cells in the master/slave unit battery pack is below 3.7 V.	Possible fault with the charging circuitry and/or battery pack.
M./S. BAT IMBALANCE	The voltage difference between the cells in the master/slave unit battery pack is too large.	The battery pack may be fault and require replacement.
M./S. eCOMPASS ERROR	The electronic compass in the master/slave unit has malfunctioned.	Replace the control board in the respective PTSU.
M./S. BAT MONITOR ERROR	The battery monitoring circuitry in the master/slave unit has malfunctioned.	Replace the control board in the respective PTSU.
M./S. BAT CHARGER ERROR	The battery charging circuitry in the master/slave unit has malfunctioned.	Replace the control board in the respective PTSU.
M./S. SLOW CHARGING	The charger connected to the respective PTSU cannot supply enough power to facilitate full charge rates.	Plug the supplied charger directly into the PTSU (no daisy chaining). If charging from a vehicle's cigarette socket, then it may not be able to supply enough power.
M./S. BACK LAMP OPEN CIRCUIT	The monitor lamp on the respective PTSU is not drawing the expected amount of power.	Check that the monitor lamp is plugged into the control board properly. Otherwise, the monitor lamp may be faulty.
M./S. BACK LAMP SHORT CIRCUIT	The monitor lamp on the respective PTSU is drawing too much power.	Check connections to the monitor lamp. Otherwise, the monitor lamp may be faulty.

APPENDIX C – HRC ERROR MESSAGES

HRC error message	Description	Remedy
HRC CRITICAL BATTERY	HRC battery level is critically low.	Plug charger into HRC.
PAIRING ERROR	The HRC is unable to connect to the respective PTSU.	Press and hold the ALL STOP button on the HRC to attempt pairing again.
M./S. COMMUNICATION ERROR	Radio link with the master/slave unit has dropped.	If this error persists, the PTSU(s) may have to be moved closer to the HRC. If this does not fix the issue, then there maybe be RF interference in the surrounding environment.
M./S. RED LAMP OPEN CIRCUIT	Red aspect on the master/slave unit is not drawing power.	Check that the aspect is plugged into the control board properly. Otherwise, the aspect may be faulty.
M./S. RED LAMP SHORT CIRCUIT	Red aspect on the master unit has drawn too much power.	Check connections to the aspect, otherwise the aspect may be faulty.
M./S. GREEN LAMP OPEN CIRCUIT	Green aspect on the master unit is not drawing power.	Check that the aspect is plugged into the control board properly. Otherwise, the aspect may be faulty.
M./S. GREEN LAMP SHORT CIRCUIT	Green aspect on the master unit has drawn too much power.	Check connections to the aspect, otherwise the aspect may be faulty.
M./S. YELLOW LAMP SHORT CIRCUIT	Yellow aspect on the master unit has drawn too much power.	Check connections to the aspect, otherwise the aspect may be faulty.
M./S. POSITION ERROR	Master/Slave unit's orientation has been displaced from its original orientation.	Rotate the unit back or set the desired orientation and press the wake switch to register the current orientation.

APPENDIX D – WAKE SWITCH LED FAULT CODES

Number of flashes	Fault	Fault description
3	Battery under/over temperature	The battery is outside of the operating temperature range and cannot be charged.
4	Cell under-voltage fault	One of the cells in the battery pack has been deeply discharged and cannot be recharged safely.
5	Cell over-voltage fault	One of the cells in the battery pack has been over charged.
6	Cell imbalance fault	The voltage difference between battery cells is large.
7	Under powered charger connected	The connected charger cannot supply enough power to the PTSU for full charge rates.
10	Internal fault	There is an internal fault with the lamp controller control board that prevents normal operation.

APPENDIX E –TROUBLESHOOTING

PTSU Common Problems

Problem	Description	Solution
PTSU Not turning ON	Battery is likely flat.	Charge the unit.
Communication issues	HRC and PTSU are unable to maintain a stable radio link.	Check status of antenna and connection to antenna. Reduce distance between the HRC and PTSU(s).
PTSU will not pair with the HRC		Refer to previous section in the manual to the pairing process.
Unit not changing from RED signal		Check communication to PTSU, as the unit will default to Red condition when failure occurs. This type of failure will also appear on the HRC
Wrong Mode		Check the Operation mode of the PTSU with the HRC.
Lamp Not illuminating		Check the wiring to the lamp and connector. This type of error will appear on the HRC when a test is performed.

If for any reason the above troubleshooting does not rectify or fix the problem, please contact us in regard to the issue.

APPENDIX F - PTSS Type 1 Spare Parts Listing

Part #	Description
BW3086	RED LED LANTERN (Type 1 modification)
BW3087	YELLOW LED LANTERN (Type 1 modification)
BW3088	GREEN LED LANTERN (Type 1 modification)
BS1089	RED LENS DOOR UNIT
BS1090	YELLOW LENS DOOR UNIT
BS1091	GREEN LENS DOOR UNIT
BS1092	DOOR UNIT CLIPS
BS1093	LANTERN SUN VISOR
BS1094	LANTERN SUN VISOR CLIPS
GT7137	PTL3 TYPE 1 PTSU MAIN CONTROLLER
GT7138	PTL3 TYPE 1 HAND REMOTE CONTROLLER
BS1181	PTL3 TYPE 1 PTSU ANTENNA
BS1182	PTL3 TYPE 1 HRC ANTENNA
GM5141	PTL3 TYPE 1 ALUMINUM HEAD TARGET BOARD (5 Pieces)
BS1183	PTL3 TYPE 1 TRIPOD (including bag)
BS1184	PTL3 TYPE 1 LOCKING PINS
BS1185	PTL3 TYPE 1 TRIPOD MOUNTING ASSEMBLY
GM5142	PTL3 TYPE 1 LAMP HEAD
BW3089	PTL- 3IL (Red Indicator Lamp)
GM5143	PTL-3SC System Connector
GM5144	PTL-3WS (Wake Up Switch)

GM5144	PTL-3PS (Power Switch)
GM5145	PTL-3 Type-1 Lamp Head Wiring Loom
GM5146	PTL-3CL Charging cable
GM5147	PTL-3PC Pairing cable
GM5148	PTL-3AA Cigarette Socket
BS1186	RF / Coaxial Cable Assembly (for aerial)
BS1187	Dust Cap cover for System Connector
GT7135	PTL3 TYPE 1 EXTERNAL BATTERY PACK
BS1179	V-LFP-12-20 LiFEPO4 12V 20A battery used in PTL3 External Battery pack
BS1180	E660 Battery Charger used for PTL3 External Battery pack
GM5140	PTL3- CC Charging Cable 4mm Banana Plugs
GM5149	PTL 3 240V – charging unit
BW3090	PTL3 HRC Case (Orange Case with foam Inserts)
BS1188	PTL3 PTSU Head Soft Case
GM	PTL3 PTSU Head Hard Case

Our specialised trained technicians are available to assist with all of the Traffic Signs NZ Ltd electronics range, plant and equipment.

We have preferred service agents available nationwide from the Far North to Invercargill, looking after over 2000 units.

Please contact our technical products team in the first instance, so they can work through the known issues and help diagnose the problem.

Once we have discussed the immediate issues, we can then advise the best course of action, or if any spare parts are required. This is usually more cost effective than taking it to a 3rd party who have no knowledge of our products.

FOR TECHNICAL SUPPORT PLEASE CONTACT OUR ELECTRONICS TEAM

SERVICE PLANNER

M: 027 365 4452

E: service@trafficsigns.co.nz

QUALITY TRAFFIC SIGNS & ACCESSORIES AT COMPETITIVE PRICES

CONTACT US NOW FOR A QUOTATION

Visit our website www.trafficsigns.co.nz



Quality
ISO 9001



Health &
Safety
ISO 45001



Environment
ISO 14001

